

SPRING 2014

# MEDIA KIT

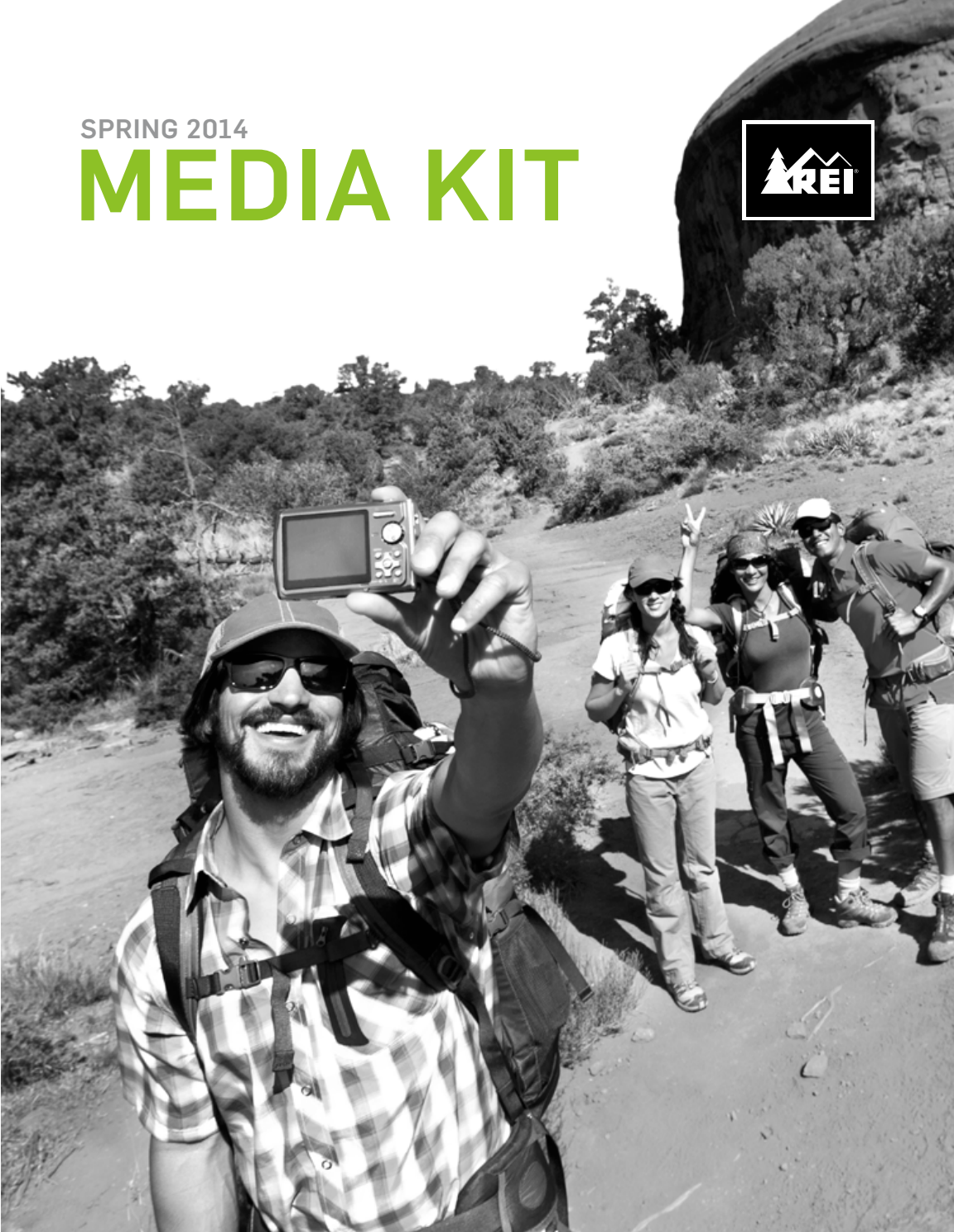

SPRING 2014

# MEDIA KIT



## KEY SPRING GEAR FROM REI

This media kit highlights some of our most intriguing new gear and apparel for spring. REI products use advanced materials, go through multiple design iterations and are evaluated using feedback from REI's comprehensive program of lab and field testing.

## THIS DIGITAL MEDIA KIT

The REI Media Kit Adobe® PDF file works with iPad® and other tablets. In addition, [REI.com/media](http://REI.com/media) provides a way to download high-resolution product images.

## NEED MORE INFORMATION?

Please contact us for additional product information, images or REI Private Brands product samples: Courtney Coe / REI Media Relations / [ccoe@rei.com](mailto:ccoe@rei.com)

HOME

CONTENTS

PACKS

TENTS/BAGS

OUTERWEAR

APPAREL

GYM/TRAVEL



#### 04 PACKS

- 05 Women's and Men's Flash Sport 15
- 06 Flash 45
- 07 Women's Flash 58/Men's Flash 62
- 08 Women's and Men's Crestrail 48
- 09 Pinnacle 35
- 10 Yosemite 75

#### 11 TENTS/SLEEPING BAGS

- 12 Dash 2 Tent
- 13-14 Quarter Dome 1, 2 & 3 Tents
- 15 Men's and Women's Flash Bags
- 16 Men's Igneo Bag/Women's Joule Bag
- 17 Men's Radiant Bags
- 18 Women's Serrana/Habanera Bags

#### 19 OUTERWEAR

- 20 Men's Kimtah Rain Jacket/Pants
- 21 Women's Chinuka Rain Jacket/Pants

#### 22 APPAREL

- 23-25 Men's Sahara Clothing
- 26-28 Women's Sahara Clothing
- 29-30 Men's/Women's Sariska Yoga Wear

#### 31 GYM/TRAVEL

- 32 Vitality Gym Duffel
- 33 Sport Beast 22"/31" Rolling Luggage
- 34 Grand Tour Packs: Women's 80/Men's 85
- 35 Vagabond Tour 40 Pack



HOME

CONTENTS

PACKS

TENTS/BAGS

OUTERWEAR

APPAREL

GYM/TRAVEL

# PACKS



## LIGHT AND SMART

### FLASH PACKS ELEVATE DAY HIKING AND MULTIDAY ADVENTURES

The REI Flash pack has been refined since its inception as an ultralight summit pack. It's grown into a line of packs for everything from trail running to backpacking.

#### THE REI FLASH COLLECTION:

FLASH 58/62: Our lightest packs for multiday trips

FLASH 45: Agile and supportive design for 2- to 4-day trips

FLASH 22: Minimalist design for light hikes and urban use

FLASH 18: Ultralight and ultra-versatile

FLASH SPORT 15: Stable, close-fitting design for fast packing and running

<a href="#">HOME</a>	<a href="#">CONTENTS</a>	<a href="#">PACKS</a>	<a href="#">TENTS/BAGS</a>	<a href="#">OUTERWEAR</a>	<a href="#">APPAREL</a>	<a href="#">GYM/TRAVEL</a>
----------------------	--------------------------	-----------------------	----------------------------	---------------------------	-------------------------	----------------------------

# PACKS



## A STABLE PACK FOR HIKING AND RUNNING

### FLASH SPORT 15

- + Contoured to fit close to the body for stability
- + Compression strap system on sides pulls load tight to the lower back
- + Stretch-mesh shoulder harness fits comfortably and breathes well
- + Stretch pockets on shoulder straps combine with zip hipbelt pockets to keep necessities accessible
- + Floating front stash pocket is big enough for a jacket
- + Hydration-compatible design fits reservoirs up to 3 liters

#### WOMEN'S

15 liters/1 lb. 1 oz.

**\$69.50**

#### MEN'S

15 liters/1 lb. 1 oz.

**\$69.50**

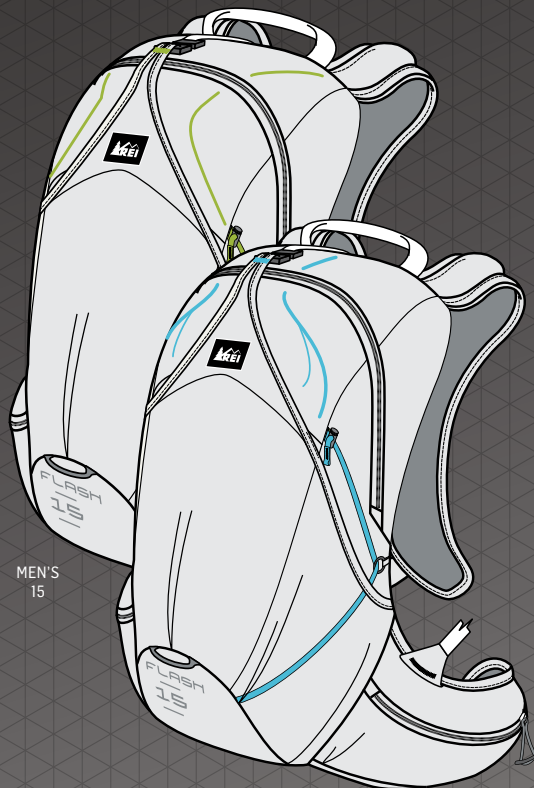

MEN'S  
15

WOMEN'S  
15

HOME

CONTENTS

PACKS

TENTS/BAGS

OUTERWEAR

APPAREL

GYM/TRAVEL

# PACKS



## AGILE, SUPPORTIVE AND ULTRALIGHT

### FLASH 45

- + Activflex LT frame's Delrin® side rods and tubular aluminum headrail allow torso rotation, yet efficiently transfer the load to the hipbelt
- + Freeflow LT back panel features sculpted ventilation channels
- + Zip hipbelt pockets and shoulder-strap pocket keep essentials handy
- + Bottles can be locked in place in angled, easy-access side pockets
- + Pack fits a BearVault™ vertically
- + Front stash pocket expands to fit a jacket, tent fly or other bulky gear
- + Lash-on features: trekking-pole tip grips and quick-clip tool loops
- + Hydration-compatible design fits most types of reservoirs



M, L

45 liters/2 lbs. 2 oz. (size M)

\$129

HOME

CONTENTS

PACKS

TENTS/BAGS

OUTERWEAR

APPAREL

GYM/TRAVEL

# PACKS



## REI'S LIGHTEST PACKS FOR MULTIDAY TRIPS

### FLASH 58/62

- + Activflex LT tubular aluminum frame allows torso rotation, yet efficiently transfers load to hipbelt
- + Freeflow LT back panel features sculpted ventilation channels
- + Structured hipbelt provides robust support for an ultralight pack
- + Zip hipbelt pockets and shoulder-strap pocket keep essentials handy
- + Bottles can be locked in place in angled, easy-access side pockets
- + Pack fits a BearVault™ vertically; front stash pocket fits a jacket
- + Hydration compatible; quick-clip tool loops; trekking-pole tip grips



### WOMEN'S 58

58 liters/2 lbs. 14 oz. (size M)

XS, S, M

**\$189**

### MEN'S 62

62 liters/2 lbs. 14 oz. (size M)

S, M, L

**\$189**

HOME

CONTENTS

PACKS

TENTS/BAGS

OUTERWEAR

APPAREL

GYM/TRAVEL

# PACKS



## ORGANIZATION AND COMFORT FOR WEEKEND TRIPS

### CRESTRAIL 48

- + Frame is light-yet-supportive tubular aluminum; torso length can be adjusted to customize the fit
- + ActivMotion™ suspension's pivoting hipbelt balances load as hips move
- + Freeflow Comfort back panel has sculpted ventilation channels
- + Triple-pocket top lid has 2 tricot-lined glasses/electronics pockets
- + Reservoir pocket is accessible from outside the pack

#### WOMEN'S

48 liters/3 lbs. 12 oz. (size M)

S, M

**\$169**

#### MEN'S

48 liters/3 lbs. 13 oz. (size M)

M, L

**\$169**



HOME

CONTENTS

PACKS

TENTS/BAGS

OUTERWEAR

APPAREL

GYM/TRAVEL

# PACKS



## ALL-MOUNTAIN PACK HAULS CLIMBING GEAR AND METAL-EDGE SKIS

### PINNACLE 35

- + Set up to carry skis, a rope, ice tools, wands and crampons
- + Durable waterproof bottom is padded to cushion pack contents
- + Detachable top straps secure a rope
- + Internal gear loops for racking and sorting climbing gear
- + Side zip offers access to main pack
- + Front crampon pocket has a drain hole and durable waterproof liner
- + Framesheet and hipbelt can be removed to cut weight
- + Each side has a top cam buckle and bottom tail loop to secure a ski
- + Pack buckles are designed to work with gloved hands and handle snow

M, L

35 liters/3 lbs. 13 oz. (size M)

**\$139**

Pinnacle 50 (not shown): \$159



HOME

CONTENTS

PACKS

TENTS/BAGS

OUTERWEAR

APPAREL

GYM/TRAVEL

# PACKS



MULTIDAY HIKERS GET  
SOLID PERFORMANCE  
AT A SOLID PRICE

## YOSEMITE 75

- + Flex-Fit suspension has a wide fit range: Torso length adjusts, as do hipbelt length and placement
- + Bottom-zip opening has flaps that open wide for access, then fold in and buckle to secure it
- + Water bottles can be locked in place in angled, easy-access side pockets
- + Large mesh pocket in front can stash a jacket or other bulky gear
- + Durable waterproof bottom protects against abrasion
- + Pack fits a BearVault™ vertically
- + Forward-pull hipbelt can be easily tightened as you hike
- + Hydration compatible; quick-clip tool loops; hipbelt pockets

M, L

75 liters/4 lbs. 12 oz. (size M)

\$179



HOME

CONTENTS

PACKS

TENTS/BAGS

OUTERWEAR

APPAREL

GYM/TRAVEL

# TENTS/BAGS



## ALL-CONDITIONS COMFORT

### NEW FOR SPRING 2014: REI SLEEPING BAGS USE WATER-REPELLENT DOWN

All REI down bags for the backcountry now feature down that has been treated to elevate its water-repellency. REI testing verifies that this treated down offers comparable loft, compressibility, weight and breathability to untreated down. The treatment significantly increases water repellency, allowing these bags to be used in a broad range of conditions.

[HOME](#)

[CONTENTS](#)

[PACKS](#)

[TENTS/BAGS](#)

[OUTERWEAR](#)

[APPAREL](#)

[GYM/TRAVEL](#)

# TENTS



## REI'S LIGHTEST 2-PERSON TENT

### DASH 2

- + Sturdy Tension Truss architecture expands headroom
- + 2 doors and 2 vestibules offer easy access and covered storage
- + Pole angles and asymmetrical tent shape maximize living space, allowing both hikers to sit up
- + A single hubbed pole assembly allows quick, easy setup
- + 15-denier ripstop nylon in tent, fly and floor minimizes weight
- + Interior pockets and hang loops help organize essentials

2 lbs. 7 oz. avg. min. weight  
29/10.6 sq. ft. tent/vestibules  
40" peak height  
2 doors/2 vestibules

**\$349**

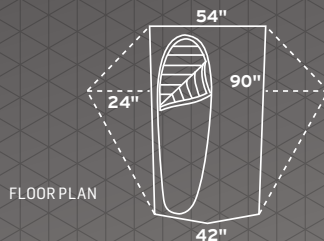
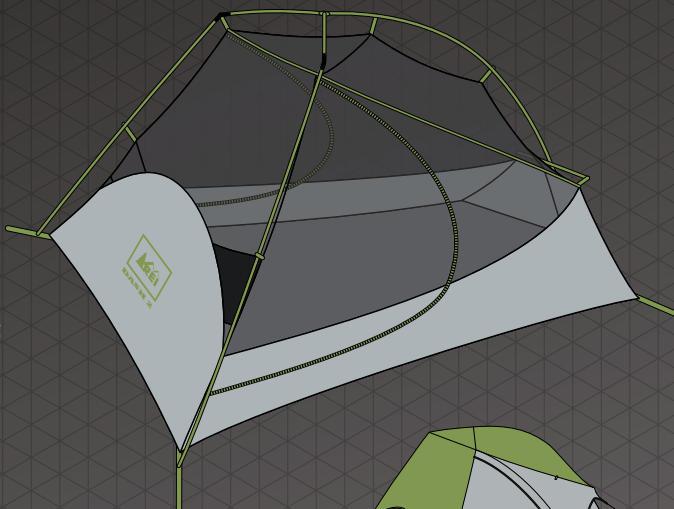

HOME

CONTENTS

PACKS

TENTS/BAGS

OUTERWEAR

APPAREL

GYM/TRAVEL

# TENTS

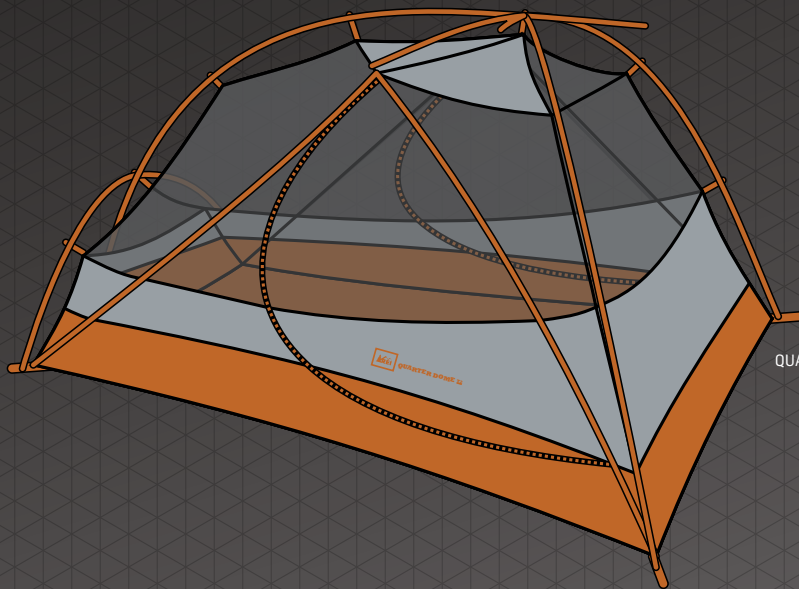

QUARTER DOME 2

## QUARTER DOMES KEEP WEIGHT LOW AND LIVABILITY HIGH

- + Sturdy Tension Truss architecture creates vertical walls, expanding headroom
- + Pole angles and asymmetrical tent shape maximize living space, so every hiker inside can sit up
- + Covered storage is provided for everyone, including a storage-only third vestibule in Quarter Dome 3
- + 15-denier ripstop nylon in tent and fly saves weight; floor is stronger 30-denier ripstop nylon
- + Large zippered roof vent on each tent helps control condensation

### QUARTER DOME 1

2 lbs. 2 oz. avg. min. weight  
21.4/6.7 sq. ft. tent/vestibule  
35" peak height  
1 door/1 vestibule  
\$219

### QUARTER DOME 2

3 lbs. 1 oz. avg. min. weight  
28.7/13.4 sq. ft. tent/vestibules  
40" peak height  
2 doors/2 vestibules  
\$299

### QUARTER DOME 3

3 lbs. 12 oz. avg. min. weight  
39.4/19 sq. ft. tent/vestibules  
42" peak height  
2 doors/3 vestibules  
\$379

FLOOR PLANS

HOME

CONTENTS

PACKS

TENTS/BAGS

OUTERWEAR

APPAREL

GYM/TRAVEL

# TENTS



## QUARTER DOME FLOOR PLANS AND DIMENSIONS

### QUARTER DOME 1 / SLEEPS 1

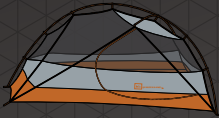

WITH FLY

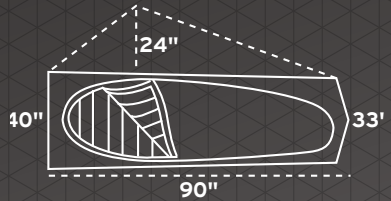

### QUARTER DOME 2 / SLEEPS 2

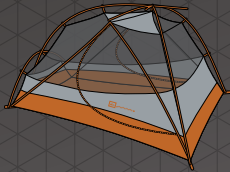

WITH FLY

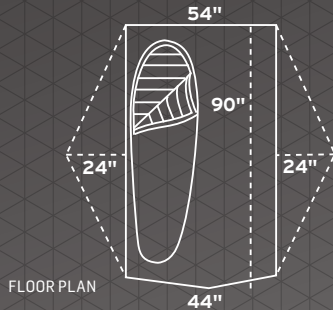

### QUARTER DOME 3 / SLEEPS 3

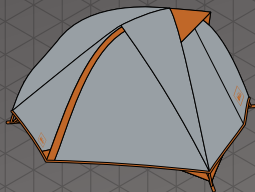
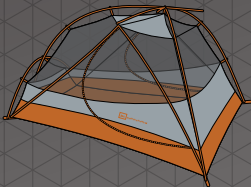

WITH FLY

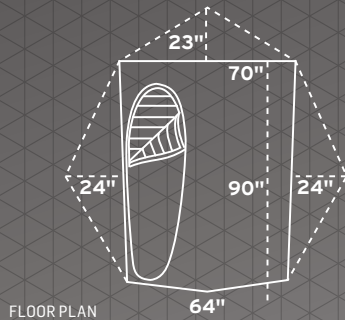

[PREVIOUS PAGE](#)

[HOME](#)

[CONTENTS](#)

[PACKS](#)

[TENTS/BAGS](#)

[OUTERWEAR](#)

[APPAREL](#)

[GYM/TRAVEL](#)

# BAGS



## DUAL-FILL ULTRALIGHT PERFORMS WELL IN DRY OR DAMP PLACES

### FLASH

- + Double protection: Ultralight wet-weather bag has water-repellent fills and strategically placed waterproof fabric
- + Water-repellent 700-fill-power duck down on top maximizes loft/warmth
- + On the bottom is PrimaLoft® Sport insulation, which performs well in a compressed under-bag space
- + Waterproof/breathable hood, side and footbox fabric offers added protection from wet tent walls

#### MEN'S

60"/55" shoulder/hip girth  
32°F target EN lower limit rating\*  
Regular/Long  
**\$259/\$269**

#### WOMEN'S

58"/58" shoulder/hip girth  
32°F target EN comfort rating\*  
Regular/Long  
**\$269/\$279**

\*Final EN ratings published January 2014

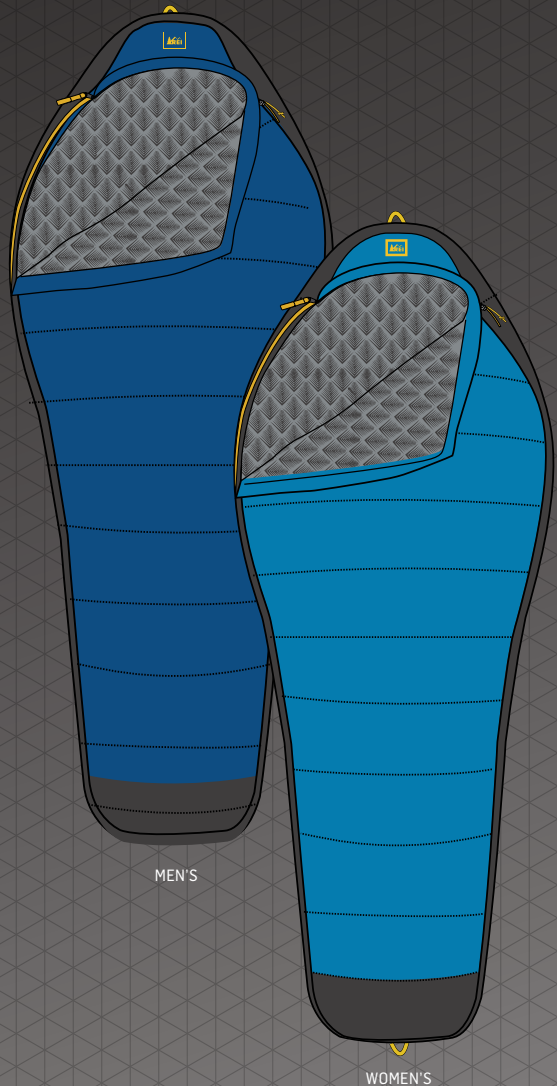

HOME

CONTENTS

PACKS

TENTS/BAGS

OUTERWEAR

APPAREL

GYM/TRAVEL

# BAGS



## DOWN WARMTH IN A WET-WEATHER DESIGN

### IGNEO/JOULE

- + Double protection: Ultralight wet-weather bag has water-repellent fills and strategically placed waterproof fabric
- + Water-repellent 700-fill-power duck down provides excellent warmth for its weight in all conditions
- + To increase loft and warmth, 60% of insulation is placed on top of bag
- + Waterproof/breathable hood, side and footbox fabric offers added protection from wet tent walls

#### MEN'S IGNEO

1 lb. 13 oz. (regular)

60"/55" shoulder/hip girth

19°F EN lower limit rating

Regular/Long

**\$299/\$319**

#### WOMEN'S JOULE

2 lbs. 2 oz. (regular)

58"/58" shoulder/hip girth

23°F EN comfort rating

Regular/Long

**\$299/\$319**

Men's 10° Magma (not shown): **\$399/\$419**

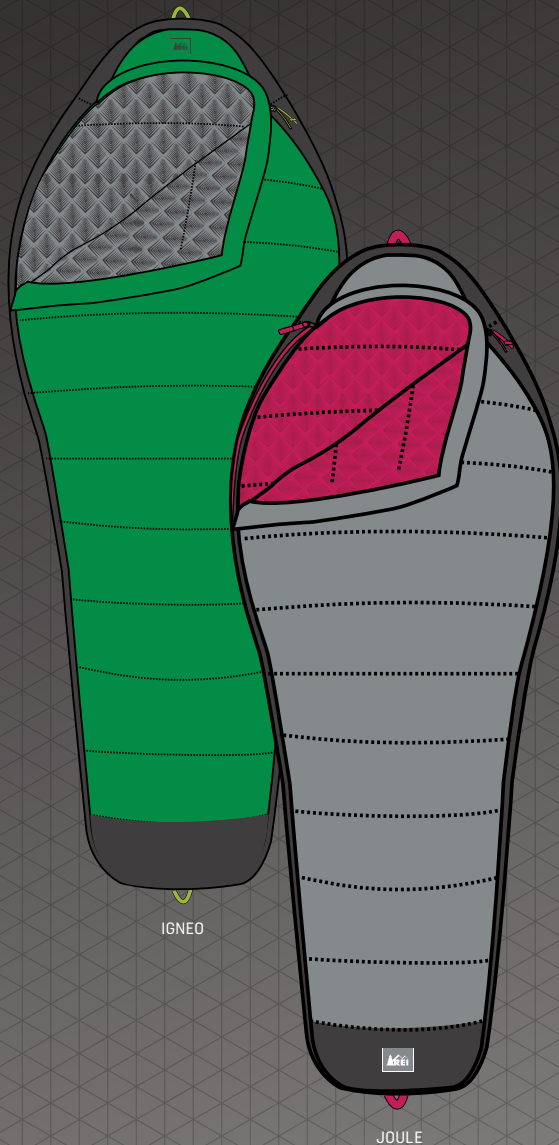

HOME

CONTENTS

PACKS

TENTS/BAGS

OUTERWEAR

APPAREL

GYM/TRAVEL

# BAGS



STILL A SOLID BUY—  
AND NOW IT HAS ALL-  
WEATHER DOWN FILL

## RADIANT

- + Water-repellent 600-fill-power duck down provides efficient warmth
- + Other performance touches include pad loops, anti-snag zipper, chest pocket, differentiated drawcords
- + Relaxed fit from shoulders to hips provides room to move
- + Plus size is for tall/big backpackers

### MEN'S RADIANT

2 lbs. 2 oz. (regular)

62"/58" shoulder/hip girth

19°F EN lower limit rating

Regular/Long

**\$199/\$209**

### MEN'S RADIANT PLUS

3 lbs. 2 oz.

70"/66" shoulder/hip girth

19°F EN lower limit rating

One Size: Long and Wide

**\$219**

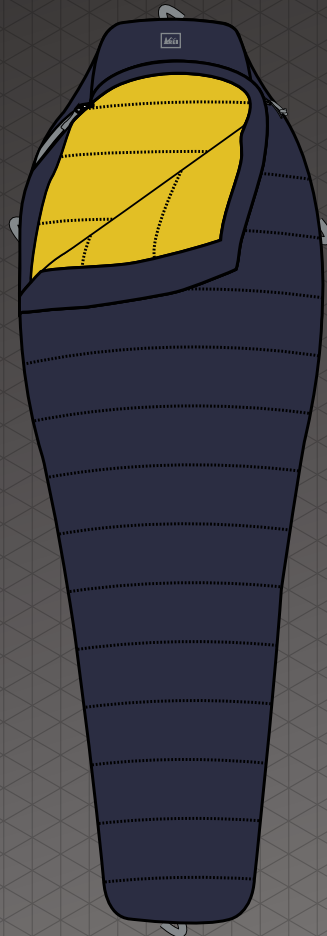

HOME

CONTENTS

PACKS

TENTS/BAGS

OUTERWEAR

APPAREL

GYM/TRAVEL

# BAGS



## ALL-WEATHER DOWN BAGS FOR COMFORT-CONSCIOUS WOMEN

### SERRANA/HABANERA

- + Water-repellent 600-fill-power duck down provides efficient warmth
- + Performance touches include pad loops, anti-snap zipper, chest pocket, differentiated drawcords
- + Relaxed fit from shoulders to hips provides room to move

#### WOMEN'S SERRANA

3 lbs. 2 oz. (regular)

60"/60" shoulder/hip girth

25°F EN comfort rating

Regular/Long

\$219/\$229

#### WOMEN'S HABANERA

3 lbs. 15 oz. (regular)

60"/60" shoulder/hip girth

13°F EN comfort rating

Regular/Long

\$279/\$289

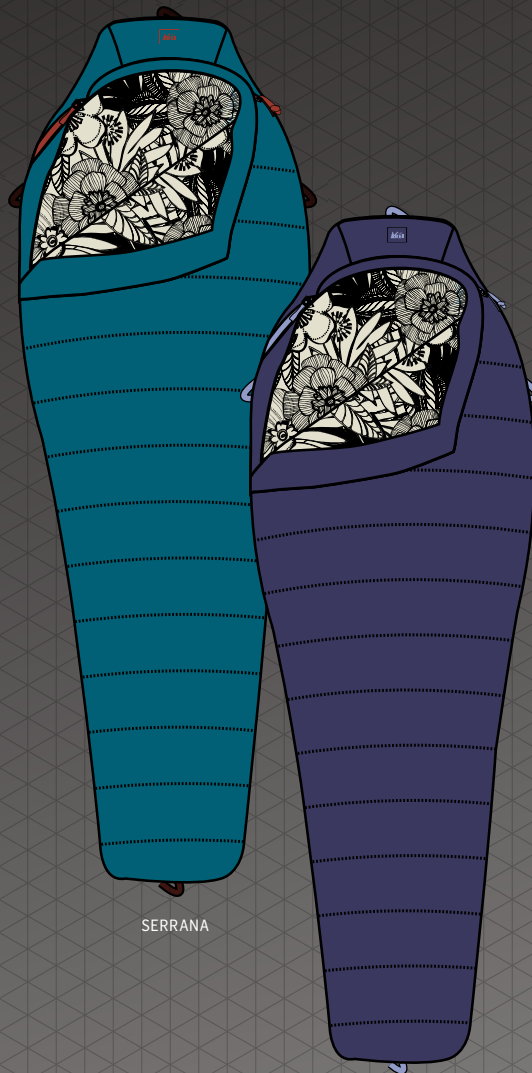

SERRANA

HABANERA

HOME

CONTENTS

PACKS

TENTS/BAGS

OUTERWEAR

APPAREL

GYM/TRAVEL

# OUTERWEAR



[HOME](#)

[CONTENTS](#)

[PACKS](#)

[TENTS/BAGS](#)

[OUTERWEAR](#)

[APPAREL](#)

[GYM/TRAVEL](#)

# OUTERWEAR



## LIGHTWEIGHT PROTECTION FOR HEAVYWEIGHT STORMS

### MEN'S KIMTAH JACKET AND PANTS

- + eVent fabric is waterproof, highly breathable and windproof up to 60 mph
- + New pit zips allow increased ventilation during high exertion
- + Outer zippers are water-resistant
- + Zip pockets stow essentials; inner zip chest pocket has a cord port
- + Pants have ankle zips and cuffs with drawcords and gaiter grommets

#### JACKET

1 lb.

**\$239**

#### PANTS

13.5 oz.

**\$189**



HOME

CONTENTS

PACKS

TENTS/BAGS

OUTERWEAR

APPAREL

GYM/TRAVEL

# OUTERWEAR



## HIGH-PERFORMANCE STORM GEAR

### WOMEN'S CHINUKA JACKET AND PANTS

- + Waterproof/breathable REI Elements®-rated fabric is windproof up to 60 mph
- + Fabric's 4-way stretch improves mobility on the trail
- + Pit zips vent excess heat and sweat
- + Outer zippers are water-resistant
- + Zip pockets stow essentials; inner zip chest pocket has a cord port
- + Pants have ankle zips and scuff guards



#### JACKET

1 lb. 1 oz.

**\$199**

#### PANTS

1 lb.

**\$149**

HOME

CONTENTS

PACKS

TENTS/BAGS

OUTERWEAR

APPAREL

GYM/TRAVEL

# APPAREL



## THE NEW REI SAHARA COLLECTION

### ADAPTABLE COVERAGE AND TECHNICAL TOUCHES

REI's essential hiking wear has grown from its iconic zip-offs into a full range of clothing. This year we redesigned favorites and added new styles. The pants resemble the original, but the fit and features are improved, along with the fabric in our men's convertible pants.

### THE SAHARA COLLECTION:

MEN'S: Convertible Pants, Cargo Pants, Cargo Shorts, Tees, Tech Shirts, Jacket, Outback Hat, Vented Outback Hat, Cadet Hat, River Cap

WOMEN'S: Shirts, Shorts, Convertible Pants, Roll-Up Pants, Hat

KIDS': Shirts, Shorts, Convertible Pants, Bucket Hat, Flap Hat

TODDLERS': Convertible Pants, Roll-Up Pants, Bucket Hat

[HOME](#)

[CONTENTS](#)

[PACKS](#)

[TENTS/BAGS](#)

[OUTERWEAR](#)

[APPAREL](#)

[GYM/TRAVEL](#)

# APPAREL



## GO-TO PANTS FOR HIKING AND TRAVELING

### MEN'S SAHARA CONVERTIBLE PANTS

- + New lightweight nylon fabric packs small, dries fast and has a durable water repellent (DWR) finish
- + Pants are also rated UPF 50+
- + No-Sit Zips make it possible to peel lower legs off without sliding them over muddy footwear
- + Center gusset and elastic in back waist ease movement
- + Soft waistband liner and flat seams increase comfort
- + Multiple pockets, many with zip closures, keep essentials handy

**\$64.50**

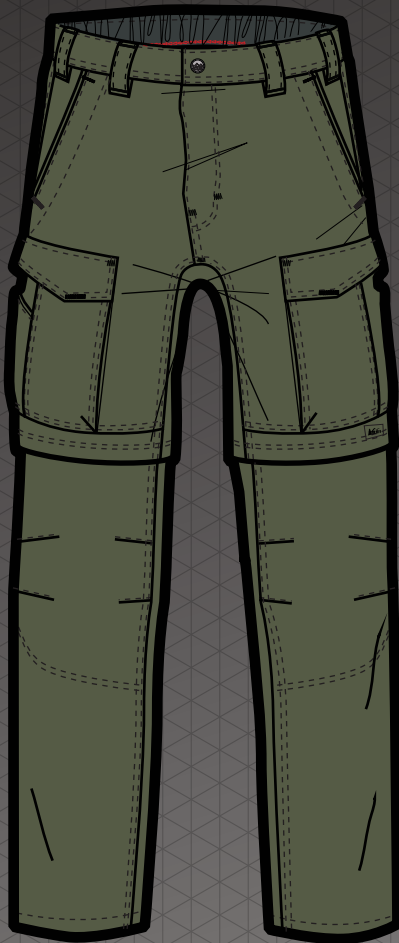

HOME

CONTENTS

PACKS

TENTS/BAGS

OUTERWEAR

APPAREL

GYM/TRAVEL

# APPAREL



## PUB- AND TRAIL-READY

### MEN'S SAHARA PLAID TECH SHIRT

- + Polyester/spandex fabric packs small, wicks sweat and dries fast
- + Also offers UPF 50+ sun protection
- + Mesh panels provide ventilation
- + Hang loop on back
- + Roomy chest pockets

**\$49.50**



HOME

CONTENTS

PACKS

TENTS/BAGS

OUTERWEAR

APPAREL

GYM/TRAVEL

# APPAREL



## MULTI-POCKETED TRAVEL COVERAGE

### MEN'S SAHARA JACKET

- + Coated nylon repels rain and is windproof up to 60 mph
- + Subtle texture has been added to the outer face to give the jacket a more urban aesthetic
- + Mesh lining increases breathability
- + 2-way front zip eases movement
- + Hood stows in collar
- + Internal zippered chest pocket has a cord port
- + Lining has a sunglasses pocket
- + Snap pockets at chest and sides; chest pocket also has a zipper
- + Also has 2 handwarmer pockets

\$99.50



HOME

CONTENTS

PACKS

TENTS/BAGS

OUTERWEAR

APPAREL

GYM/TRAVEL

# APPAREL



## ROLL, TAB, GO: HIKERS PICK THE LENGTH

### WOMEN'S SAHARA ROLL-UP PANTS

- + Pants roll up to cropped or capri length; button tabs secure them
- + Scuff guards protect cuffs when pant legs are all the way down
- + Polyester/spandex stretch fabric wicks moisture and dries fast
- + Fabric also has a UPF 50+ rating
- + Multiple pockets for essentials; cargo and 1 back pocket have zips
- + Soft tricot waistband lining wicks moisture
- + Center gusset and articulated knees ease movement

**\$69.50**

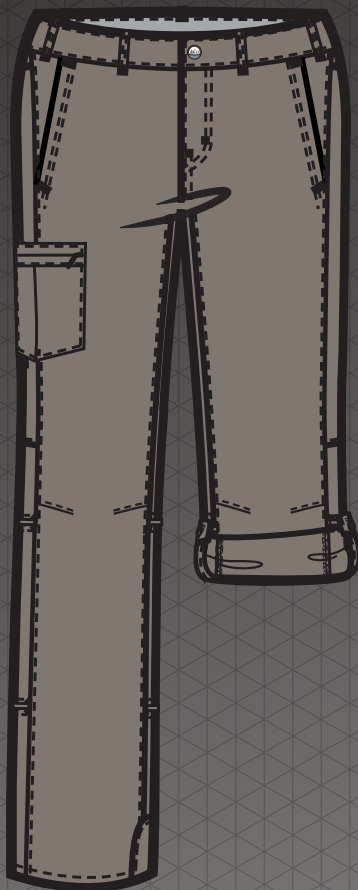

HOME

CONTENTS

PACKS

TENTS/BAGS

OUTERWEAR

APPAREL

GYM/TRAVEL

# APPAREL



## NO-SIT ZIPS MAKE SHORT WORK OF CONVERSIONS

### WOMEN'S SAHARA CONVERTIBLE PANTS

- + No-Sit Zips make it possible to peel lower legs off without sliding them over muddy footwear
- + Lightweight nylon fabric packs small, dries fast and has a durable water repellent (DWR) finish
- + Pants are also rated UPF 50+ and wrinkle-resistant
- + Center gusset and elastic in back waist ease movement
- + Soft waistband liner and flat seams increase comfort
- + Plenty of pockets, all with drainage

**\$64.50**

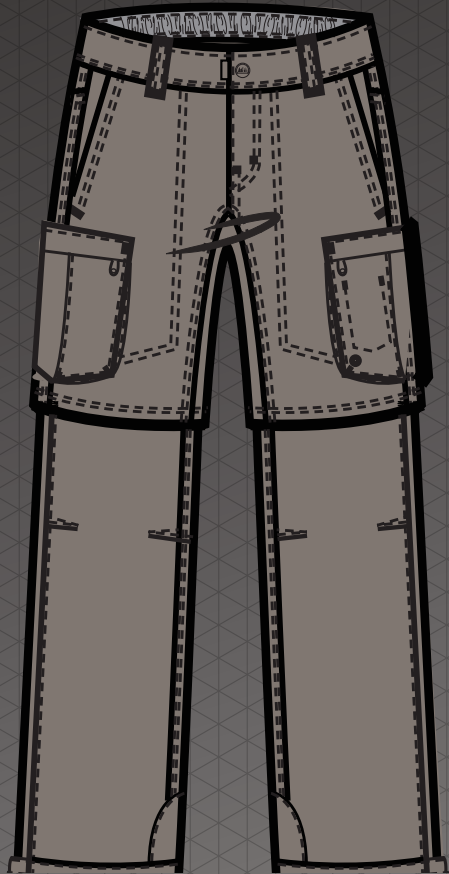

HOME

CONTENTS

PACKS

TENTS/BAGS

OUTERWEAR

APPAREL

GYM/TRAVEL

# APPAREL



## A SMART CHOICE FOR HIKING AND TRAVELING

### WOMEN'S SAHARA LONG-SLEEVE SHIRT

- + UPF 50+ fabric, sun collar and sun cuffs offer excellent UV protection
- + Lightweight polyester also wicks moisture and stretches comfortably
- + Back yoke vent and 2 zip vents on sides provide air circulation
- + Zip chest pockets have mesh pocket bags that let them double as vents
- + Zip document pocket is hidden under the front placket
- + Sunglasses loop on front yoke seam
- + Seam-free shoulder design prevents abrasion under pack straps

\$54.50



HOME

CONTENTS

PACKS

TENTS/BAGS

OUTERWEAR

APPAREL

GYM/TRAVEL

# APPAREL



## FOR THE YOGA MAT AND BEYOND

### MEN'S SARISKA FULL-ZIP JACKET

- + Active fit and 4-way-stretch fabric provide a full range of motion
- + Moisture-wicking mesh lining dries quickly
- + Thumb holes help keep sleeves in place during movement
- + Zip pockets secure essentials; 1 includes a cord port

\$74.50

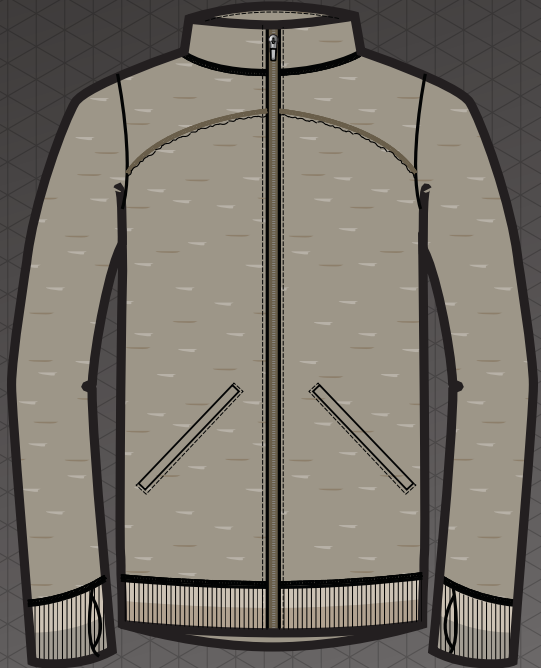

HOME

CONTENTS

PACKS

TENTS/BAGS

OUTERWEAR

APPAREL

GYM/TRAVEL

# APPAREL



FOR WARM-WEATHER  
YOGA SESSIONS

## WOMEN'S SARISKA TANK

- + Soft fabric wicks moisture, dries fast and has a UPF 50+ rating
- + Mesh lining also wicks moisture
- + Internal bra has soft elastic and molded, removable cups that provide good fit and support

\$49.50



HOME

CONTENTS

PACKS

TENTS/BAGS

OUTERWEAR

APPAREL

GYM/TRAVEL

# GYM/TRAVEL



[HOME](#)

[CONTENTS](#)

[PACKS](#)

[TENTS/BAGS](#)

[OUTERWEAR](#)

[APPAREL](#)

[GYM/TRAVEL](#)

# GYM

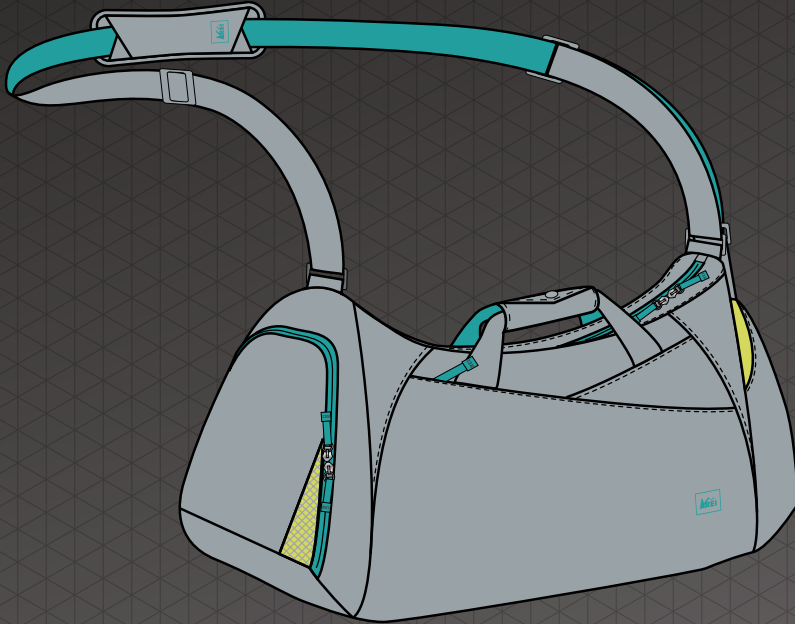

## THE PACKING SOLUTION FOR DAILY WORKOUTS

### VITALITY GYM DUFFEL

- + Single straight zipper gives direct access to main compartment
- + Vented compartment separates shoes and damp gear from other contents
- + Zip pocket has fleece-lined slot pockets for stashing a phone, music player or small accessories
- + Large side pocket can hold a 1-liter bottle, umbrella or hat and gloves
- + Adjustable padded shoulder strap and grab handles with wrap closure offer carrying options

1 lb. 9 oz.

20" x 14" x 11"

\$69.50

HOME

CONTENTS

PACKS

TENTS/BAGS

OUTERWEAR

APPAREL

GYM/TRAVEL

# TRAVEL



## NEATLY SEPARATES OUTDOOR WEAR FROM INDOOR ATTIRE

### SPORT BEAST

- + Clamshell opening gives full access; zip panel on each half separates city apparel from recreational gear
- + REI's lightest rolling luggage uses lightweight Cordura® nylon
- + Molded EVA foam on back half provides structure
- + Includes lock-compatible zippers and an ID window that's only accessible via an inner zip pocket
- + Add-a-bag hook on front allows easy attachment of ride-along pieces; kickstand lets it park upright

22"

6 lbs. 7 oz.

22" x 14" x 10" (carry-on size)

**\$179**

31"

9 lbs. 9 oz.

31" x 16" x 15"

**\$249**



HOME

CONTENTS

PACKS

TENTS/BAGS

OUTERWEAR

APPAREL

GYM/TRAVEL

# TRAVEL



## CARRYING COMFORT AND TRAVEL-SAVVY FEATURES

### GRAND TOUR

- + Technical shoulder harness and waistbelt are contoured for comfort
- + Includes a travel/rain cover
- + Torso adjustment fine-tunes fit
- + Outer zippers are lock-compatible
- + Inner compression straps and pockets help organize belongings
- + Detachable daypack has roomy main compartment, organizer panel and neoprene sleeve for a 13" laptop
- + Daypack can attach to the front straps to keep valuables in view

Women's 80  
5 lbs. 8 oz.  
26" x 14.5" x 10"  
**\$189**

Men's 85  
5 lbs. 12 oz.  
28" x 14.5" x 10"  
**\$189**



MEN'S 85

INCLUDED DAYPACK  
SLIPS INTO FRONT  
STASH POCKET

HOME

CONTENTS

PACKS

TENTS/BAGS

OUTERWEAR

APPAREL

GYM/TRAVEL

# TRAVEL



CARRIES WELL ON  
TRAINS, PLANES  
AND TRAILS

## VAGABOND TOUR 40

- + Has a comfortable backpack-style shoulder harness and waistbelt
- + Zip panel covers harness and belt, so pack can slide into overhead bins
- + Zip front panel provides wide-open access to contents
- + Outer zippers are lock-compatible
- + Inner compression straps help maximize cargo capacity
- + Inner fabric sleeve can fit a laptop
- + Top organizer pocket has a key clip and a pocket with soft lining

2 lbs. 8 oz.

24.5" x 10" x 7"

\$119

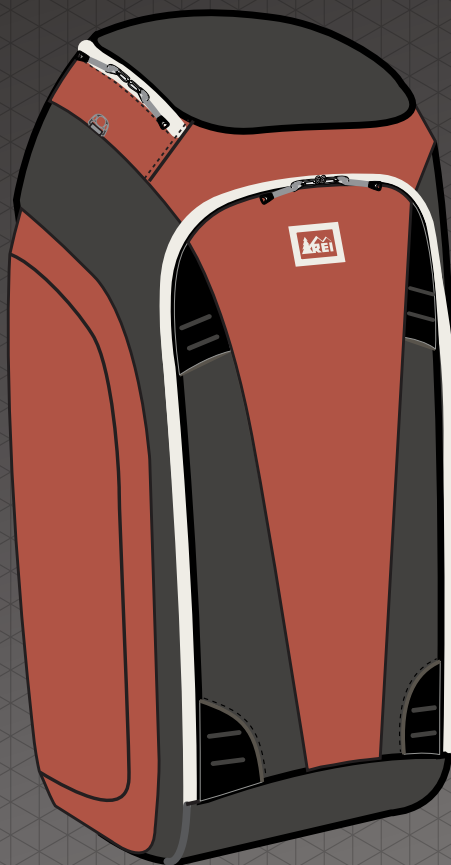

HOME

CONTENTS

PACKS

TENTS/BAGS

OUTERWEAR

APPAREL

GYM/TRAVEL